

CmStick/T



Article-No:
1001-02-2xx

Description

The CmStick/T is the heart of the CodeMeter Digital Rights Management system as USB device in a very small and noble case. It contains a SmartCard chip including a secure memory of about 384 kbyte available for storing thousands of licenses. The basic idea of the revolutionary CodeMeter concept is that licenses can be stored for many products even from many different vendors at the same time.

The CmStick/T contains a high accurate real time clock (RTC). With the embedded battery, the power-off time is bridged. When the CodeMeter Stick is plugged in, the RTC is used to synchronize the CodeMeter System Time to the future. The advantages of the Smart Card chip internal clock is combined with the RTC. If the battery is tampered or fails, the time handling still works like in a standard CmStick.

License Options are: Text (description of an entry), Unit Counter (number of runs or actually run time of a license), Activation Time (the license is valid from), Expiration Time (the license is valid until), Usage Period (starts at first time), Maintenance Period (according to release date), Feature Map (up to 32 modules or versions), License Quantity (concurrent use / floating network licenses), Protected Data / Extended Protected Data (128x256 bytes read-only data), Hidden Data (128x256 bytes only readable with password; usable as secret/private key), Secret Data (128x256 bytes non-readable, only usable as secret/private key), User Data (unsecured 256 bytes), Customer Owned License Information (256 bytes).

Used algorithms: 128 bit AES, SHA-256, 2048 bit RSA, 224 bit ECC.

The used SmartCard chip contains a random number generator according to FIPS140-1 and fulfills EAL 4+ (Common Criteria certified). The CmStick/T has a green and a red LED.

Technical Specifications

The CodeMeter technology is covered by US 7.145.297 and other patents.

- **Interface: Hi-Speed USB 2.0 certified, USB 1.1 compatible**
- **CodeMeter License memory:**
 - **Data retention: 10 years at room temperature**
 - **Data endurance:**
 - **Unit Counter: up to 5 billion decrements**
 - **Other license parameter: up to 10 million updates to one license**
- **Power supply: 5 V bus-powered, < 20 mA (LEDs off), < 60 mA (both LEDs on)**
- **Temperature: 0...55 degree C, non-condensing**
- **MTBF (Mean Time Between Failures): > 3 Million hours**
- **Real Time Clock inaccuracy: < ±1 minute/month @25 degree C**
- **Case/Dimensions: Noble plastic case, 8 mm x 16 mm x 52,5 mm, Stick with protective cover: 12 mm x 25 mm x 88 mm**
- **Weight: CmStick/T 6g, Cover 8g, CmStick/T ME 19g, metal cup 5g**
- **Warranty: 36 months**

Certificates

The CmStick/T is tested and qualified with the following standards:

■ CE-Conformity | European Certificates

Radiated emissions 150 kHz...6 GHz:

- EN 55022:2006 + A1:2007
- IEC/CISPR 22:2005, modified + A1:2005 limits for Class B equipment

Immunity: Radiated RF electromagnetic field, electrostatic discharge, injected currents (RF) unsymmetrical and fast transients (burst) unsymmetrical:

- EN 55024:1998 + A1:2001 + A2:2003
- IEC/CISPR 24:1997, modified + A1:2001 + A2:2002

The detailed test report from VDE Testing and Certification Institute, File 2387800-3250-0002/120746, 2009-09-08 is available on request.

■ International Certificates

FCC Part 15, Subpart B, File 09047-AU01+E01

VCCI 2003-04 (Japan)

KCC 7UNR-XW14-FC11-AWGX, XWK-1001-02-xxx (A) (South Korea)

■ Other Certificates

Listed on USB Integrators List.

VDE License No. 129382

C-UL-US listed I.T.E. Accessory 10 WB, E-File 211202

The encryption device is only for use with UL Listed PCs (low power system). Meets UL 60950-1 and CSA C22.2 No. 60950-1 Safety of Information Technology Equipment.

SGS testing report CE/2008/B5773, December 2008

All CmSticks/T are fully compliant according to EC Directives 2002/95/EC (RoHS) and 2002/96/EC (WEEE).

Ordering Information

P/N 1001-02-230: CmStick/T ME, metal case

P/N 1001-02-200: CmStick/T bulk, plastic case

P/N 1610-5018: Cover with clamp | RAL 5018

Variants with individual cases, colors or labels on request.



방송통신위원회



RoHS compliant
WEEE-Reg-No:
DE 90465365

All dimensions in millimeter.
Subject to change without
notice.

CmStick/T plastic

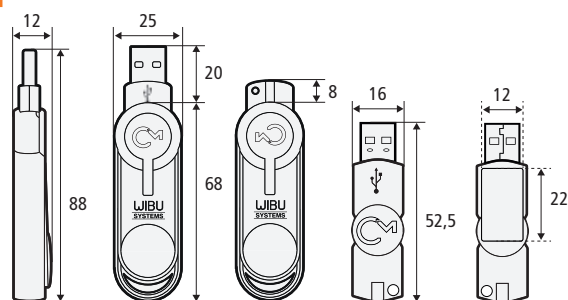

CmStick/T metal

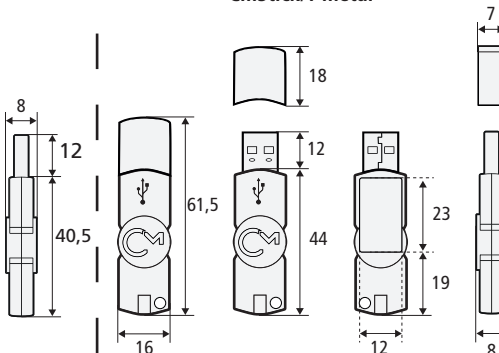

WIBU-SYSTEMS AG
Rueppurrer Strasse 52-54
D-76137 Karlsruhe
Tel: +49-721-93172-0
Fax: +49-721-93172-22
info@wibu.com
www.wibu.com

WIBU
SYSTEMS